

Pinetree Electronics Ltd  
Tel: +1-604-9001068  
E-mail: support@osoyoo.info

**Manufacture:** Pinetree Electronics Ltd  
**Address:** 9180 Wellmond Road, Richmond, BC V7E1L5, Canada

**EC** **Name:** APEX ES SPECIALISTS, S.L.

**REP** **Address:** Calle Puerto de la Morcuera, 13, PL. 1 OF.  
18-8 28919 Leganés Madrid

**UK** **Name:** OSOYOO ELECTRONICS (UK) LTD  
**Address:** UNIT G25 WATERFRONT STUDIOS, 1 DOCK ROAD,  
**REP** LONDON, E16 1AH, UNITED KINGDOM



OSOYOO

SKU:2023003100

Made in China

# ULTRASONIC LEVITATION DIY KIT



Online Tutorial URL:  
<https://osoyoo.com/?p=56309>

### Customer Service and Tech Support:

You have following two options to ask for help:

1) Leave comments on our tutorial:

<https://osoyoo.com/?p=56309>

2) send email to [support@osoyoo.info](mailto:support@osoyoo.info)

We guarantee that all inquiries will be replied in 24 hours.

3) Please visit the link to watch the video:

<http://osoyoo.com/2023003100.html>



Video



Tutorial

## Content :

<b>Overview</b> .....	1
Introduction.....	1
Working Principle.....	1
Parameter.....	1
Note.....	2
<b>Schematic Diagram</b> .....	2
<b>Component Listing</b> .....	3
<b>PCB Assembly</b> .....	5
<b>Safety Precautions</b> .....	18
安全注意事項.....	18
Sicherheitsvorkehrungen.....	19
Précautions de sécurité.....	19
Misure di sicurezza.....	20
Precauciones de seguridad.....	20

## Overview

### 1.Introduction:

This is a Ultrasonic Levitation DIY Kit .

It will help you practice soldering skills, to become familiar with a variety of electronic components, and provide you with dynamic results. If the circuit has been assembled and soldered properly, LED will light on, and four balls will levitate.

### 2.Working Principle:

Ultrasonic standing wave suspension is that there is a certain distance between the ultrasonic transmitting end and the reflecting end (or another transmitting end) (called the resonant cavity distance),and the transmitted wave and the reflected wave (or another acoustic wave) are continuously superimposed to form a standing wave. The acoustic wave force on the object at the standing wave node overcomes the effect of gravity and finally achieves the effect of suspension.

### 3.Parameter:

- 1>.Item name: Ultrasonic Levitation DIY Kit
- 2>.Work voltage: DC 12V
- 3>.Diameter of suspended solids: 2~3mm
- 4>.Size(Installed):44\*40\*66mm

1

### 4.Note:

- 1>.Light and small objects are required for suspension. Otherwise, they cannot be suspended.
- 2>.The ultrasonic transmitters are sensitive to vibrations, so avoid dropping or colliding with them. After soldering the ultrasonic transmitters, do not cut off any excess metal pins.
- 3>.As the suspension is too light, it may be affected by the wind, so please place the welded unit in a place where there is little wind to work in!

## Schematic Diagram:

Please visit online tutorial to learn more about schematic diagram:  
<https://osoyoo.com/?p=56309>

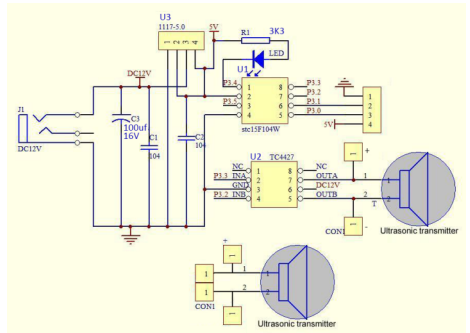

2

## Component listing

NO.	Component Name	Value	Symbol	QTY
1	Main PCB+Top PCB			1
2	IC1(STC15F104)		U1	1
3	IC2(TC4427)		U2	1
4	IC3(AMS1117-5.0)		U3	1
5	Ceramic capacitor	100nF	C1 C2	2
6	Electrolytic Capacitor	100uF	C3	1
7	LED		LED	1
8	Resistor	3.3kΩ	R1	1
9	Power Socket		J1	1
10	Ultrasonic transducer		TX	2
11	Copper pillars (M2*17mm)			6
12	Copper pillars (M2*30+3mm)			2
13	DC 5V to 12V USB cable			1
14	M2 screws			8
15	Foam balls			6
16	Screwdriver			1

3

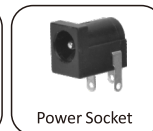
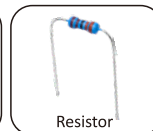
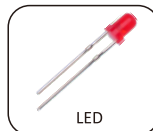
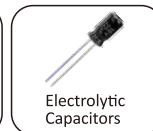
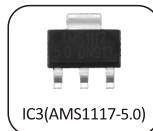
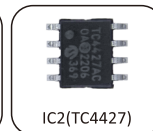
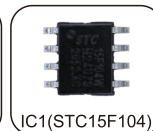
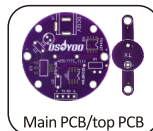

4

## PCB ASSEMBLY :

**Step1.** Mount IC2( TC4427) on U2.

1.1) Be sure that the dot on the IC is in the same direction as the marking on the PC board.

(Ps: Be extremely careful in the orientation of the IC.)

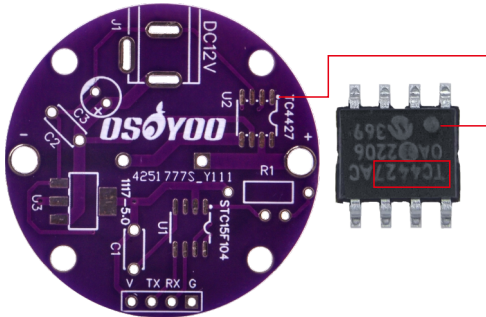

1.2) Select a solder pad on the PCB, then put solder on the pads.

5

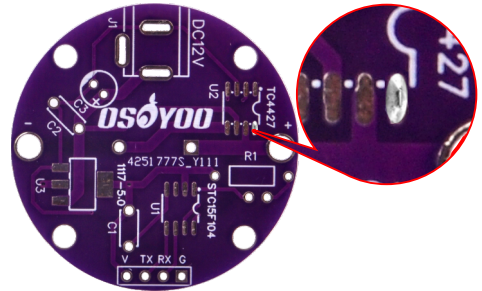

1.3: Use a tweezer to put the IC2(TC4427) on it, and hold in place. Then touch the soldering iron to one leg of the IC and let it melt the solder and get attached.

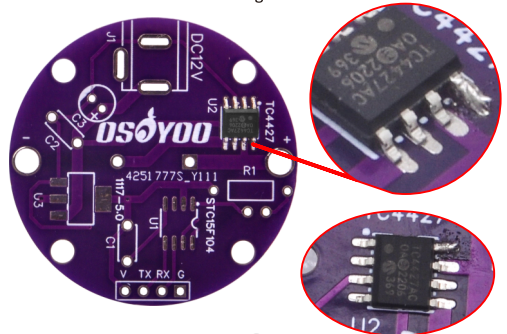

6

1.4:Solder the rest legs of the IC2(TC4427).

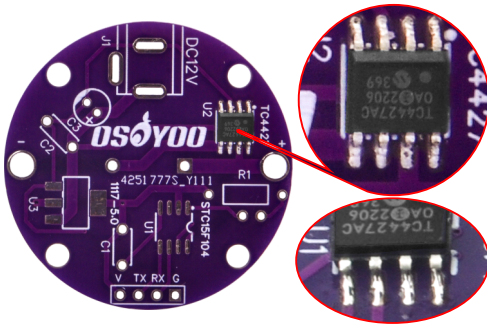

**Step2.**Mount IC1( STC15F104) on U1 using the same method .  
Be sure that the dot on the IC is in the same direction as the marking on the PC board.

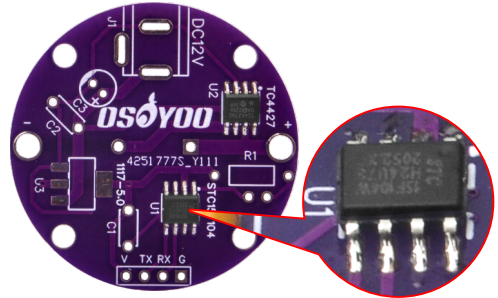
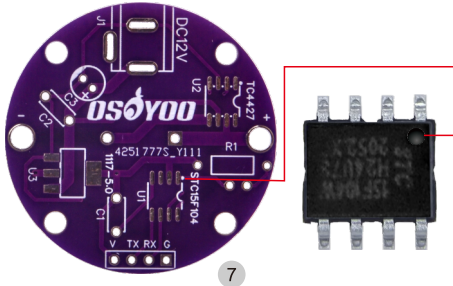

**Step3.**Mount IC3( AMS1117-5.0) on U3 using the same method .

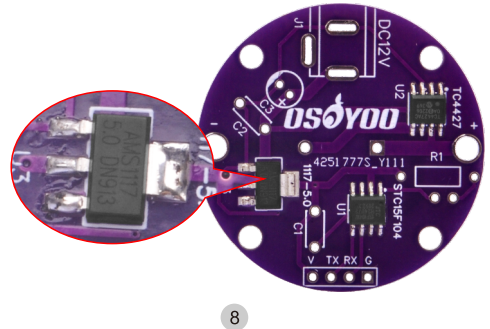

**Step4.** Mount 2pcs 100nF ceramic Capacitors on C1 and C2.  
Solder and cut off the excess leads.

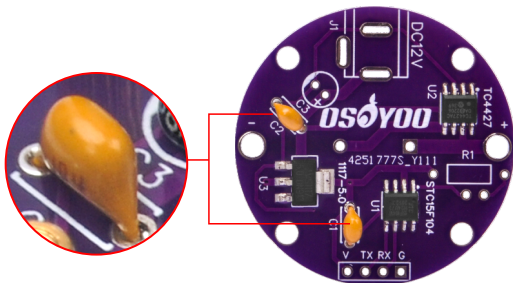

**Step5.** Mount a 100uF Electrolytic Capacitor on C3.

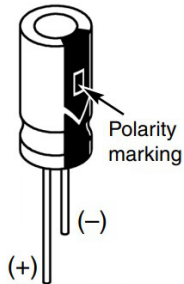

(Ps:Electrolytic capacitors have a positive and a negative electrode.Be sure to mount the Positive (+) of electrolytic capacitor to the hole marked(+) on the PC board.)

Warning: If the capacitor is connected with incorrect polarity,it may heat upand either leakor cause thecapacitor to explode.

Solder and cut off the excess leads.

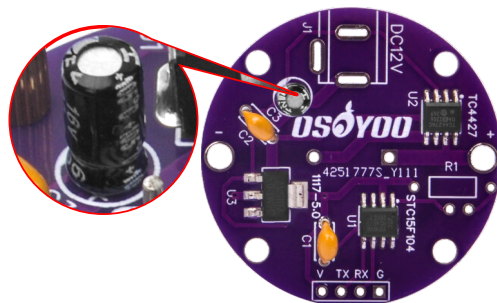
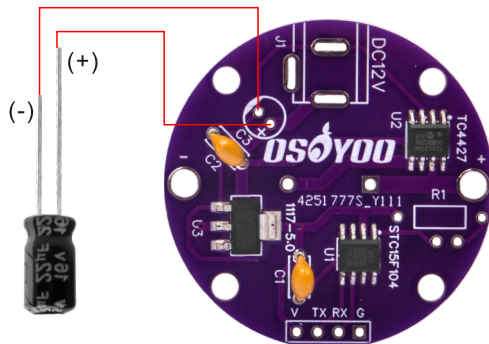

**Step6.** Mount a resistor on R1.  
Solder and cut off the excess leads.

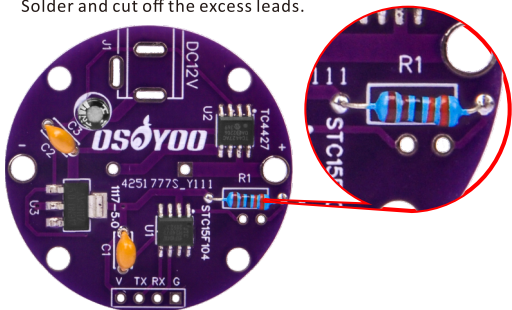

**Step7.** Mount power socket on J1 and Solder .

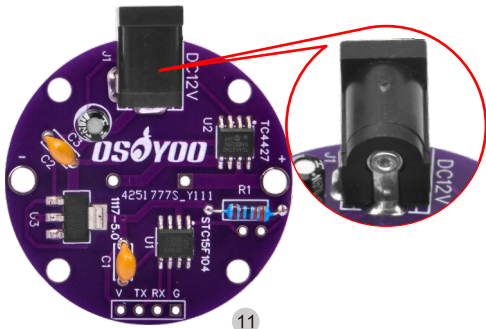

**Step8.** Mount LED on the other side of PCB.  
(Ps:LED have polarity.Be sure to mount the Positive (+)  
of LED to the hole marked(+) on the PC board.)  
Solder and cut off the excess leads.

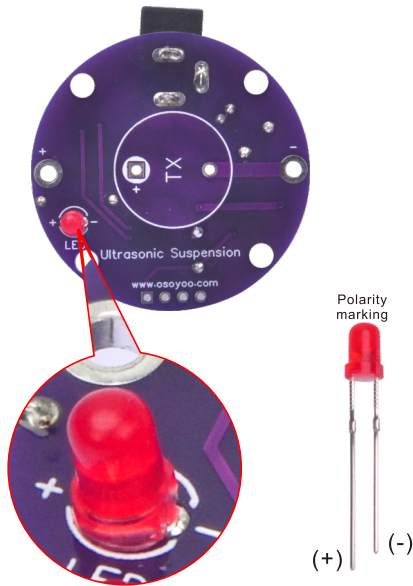



**Step9.**Mount a Ultrasonic transducer on PCB.

Ps:Ultrasonic transducer has two pins. One has a black circle around it, that' the positive (+) leg,put that in the hole marked (+) on the PC board.

Solder and **keep** the metal pins.

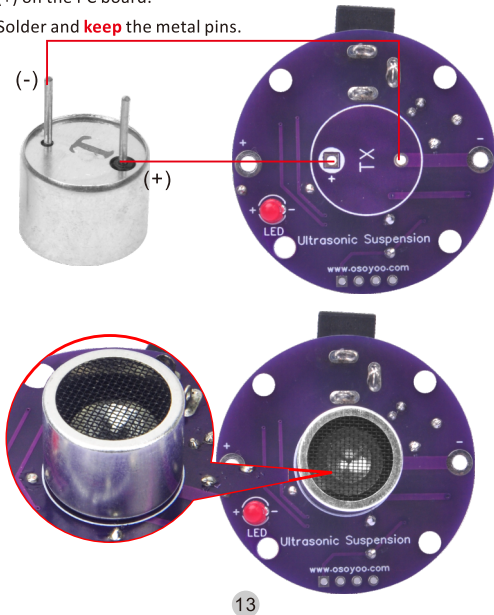

**Step10.**Mount the other Ultrasonic transducer on top PCB.  
Solder and **keep** the metal pins.

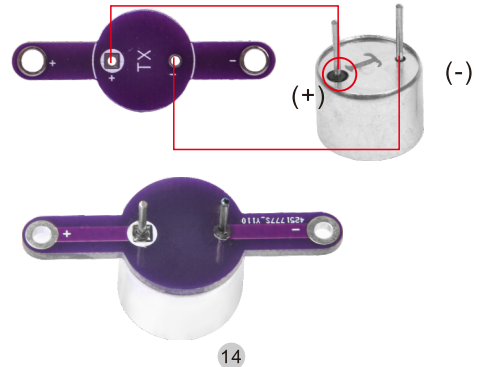

**Step11.** Fix M2\*17mm Copper Pillars on the main PCB by M2 screws.



The other side

**Step12.** Splices M2\*17mm Copper Pillars and M2\*30+3mm Copper Pillars to a whole Copper Pillars.

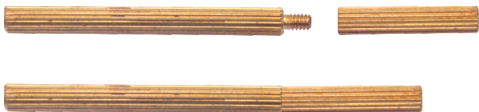

15

**Step13.** Fix top PCB on main PCB with 2PCS Pillars from last step and 4pcs M2 screws.

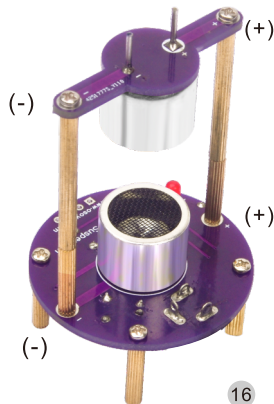
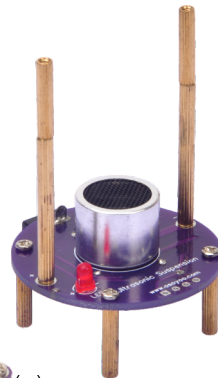

Note that the positive electrodes of the two PCB correspond to each other.

16

#### Step14.Operation:

After completing the assembly of the kit, double check that the soldering looks good and all of the components are in their proper place.

Note: The USB cable in the package can boost the 5V voltage to 12V, and can be directly connected to the computer USB port to power the product.

If everything is all right power it via USB cable, LED will light on. Use the tweezers to place the included foam balls into place.

Have fun and enjoy the science and technology---  
to levitate the foam ball.

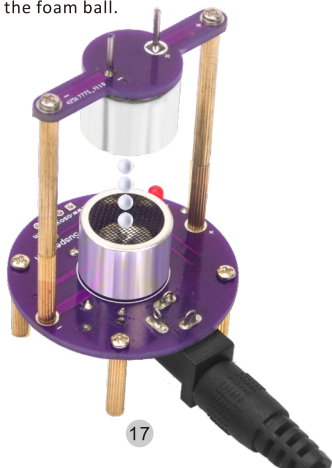

#### Safety Precautions

Like all electrical devices, the solder station must be handled with care. The soldering iron and tip can reach high temperatures and these simple safety rules should be followed.

- Keep kids out of reach of the soldering station.
- Keep flammable material away from the soldering iron.
- DO NOT cool iron by dipping it into any liquid or water.
- Work in an area that is well ventilated.

#### 安全注意事項

すべての電気機器と同様に、はんだステーションも注意深く取り扱う必要があります。はんだごてと先端部は高温になる可能性があり、これらの簡単な安全ルールに従うべきです。

- はんだステーションを子供の手の届かない場所に保管してください。
- ごてを液体や水に浸して冷却しないでください。
- 熱いはんだごての先が電源コードに触れないように注意してください。
- 十分な換気が行われているエリアで作業してください。

### Sicherheitsvorkehrungen

Wie bei allen elektrischen Geräten muss die Lötstation sorgfältig behandelt werden. Das Lötisen und die Spitze können hohe Temperaturen erreichen, und diese einfachen Sicherheitsregeln sollten befolgt werden.

- Halten Sie Kinder von der Lötstation fern.
- Halten Sie brennbare Materialien von dem Lötisen fern.
- Kühlen Sie das Eisen NICHT ab, indem Sie es in Flüssigkeit oder Wasser eintauchen.
- Arbeiten Sie in einem gut belüfteten Bereich.

### Précautions de sécurité

Comme tous les dispositifs électriques, la station de soudage doit être manipulée avec précaution. Le fer à souder et la pointe peuvent atteindre des températures élevées et ces règles de sécurité simples doivent être suivies.

- Gardez les enfants hors de portée de la station de soudage.
- Éloignez les matériaux inflammables du fer à souder.
- NE refroidissez PAS le fer en le plongeant dans un liquide ou de l'eau.
- Travaillez dans un espace bien ventilé.

### Misure di sicurezza

Come tutti i dispositivi elettrici, la stazione saldante deve essere maneggiata con cura. Il ferro da saldatura e la punta possono raggiungere alte temperature e queste semplici regole di sicurezza dovrebbero essere seguite.

- Mantenere i bambini fuori dalla portata della stazione saldante.
- Tenere materiali infiammabili lontano dal ferro da saldatura.
- NON raffreddare il ferro immergendolo in liquidi o acqua.
- Lavorare in un'area ben ventilata.

### Precauciones de seguridad

Al igual que con todos los dispositivos eléctricos, la estación de soldadura debe manejarse con cuidado. El soldador y la punta pueden alcanzar altas temperaturas y se deben seguir estas simples normas de seguridad.

- Mantener a los niños fuera del alcance de la estación de soldadura.
- Mantener los materiales inflamables alejados del soldador.
- NO enfriar el hierro sumergiéndolo en líquidos o agua.
- Trabajar en un área bien ventilada.